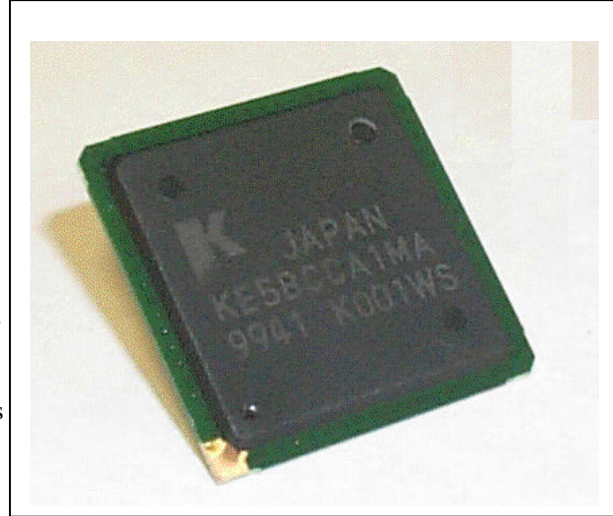

**KE5BCCA1M****Classification CAM**

Kawasaki LSI's Classification CAM has a capacity of 1Mbit (Ternary) and 2 Mbit (Binary), and can be configured by bank in a mixture of binary and ternary modes. Its primary application is in search and filtering. Its flexibility, high speed, and high capacity make it appropriate for all Layer 2/3/4 and above applications such as switches and routers in 10/100/1000 Ethernet, Terabit Ethernet, OC-3/12/48/192, T1/T3, frame relay, ATM, xDSL and DWDM.

This Classification CAM is also suitable for QoS applications with its unique and patent-pending "Auto Shift" commands.

The search time is 15ns and the KE5BCCA1M is available in a 324-pin BGA.

**FEATURES:**

- High density: 2Mbits Binary, 1Mbit for Ternary
- Organization: Configurable table width; binary/ternary selected by bank
- Binary case: 68-bit x 32k, 136-bit x 16k, 272-bit x 8k
- Ternary case: 68-bit x 16k, 136-bit x 8k, 272-bit x 4k
- High Speed Search :15n sec (1 phase clock)
- Latency: 30n sec (2 clock cycles)
- Dual-Port Architecture: 68-bit I/O port with
 1. 64-bit data bus (optional 32-bit configuration)
 2. Optional 4 extra bits on the data bus
 3. 32-bit output port
- Cascadable up to 32 pieces
- Support for automatic data shifting
- Continuous search during data shifting.
- Multi-hit support (highest hit address output)
- 18 Global MASK Registers (68-bit width) for data search/writing operation.
- Automatic learning
- Automatic storing of miss-hit data and time stamp of hit data
- Synchronous operation
- Clock rate: 66MHz (phase clock)/133MHz (operating clock) for synchronous operation
- 324-pin BGA packaging
- 2.5V/3.3V power supply

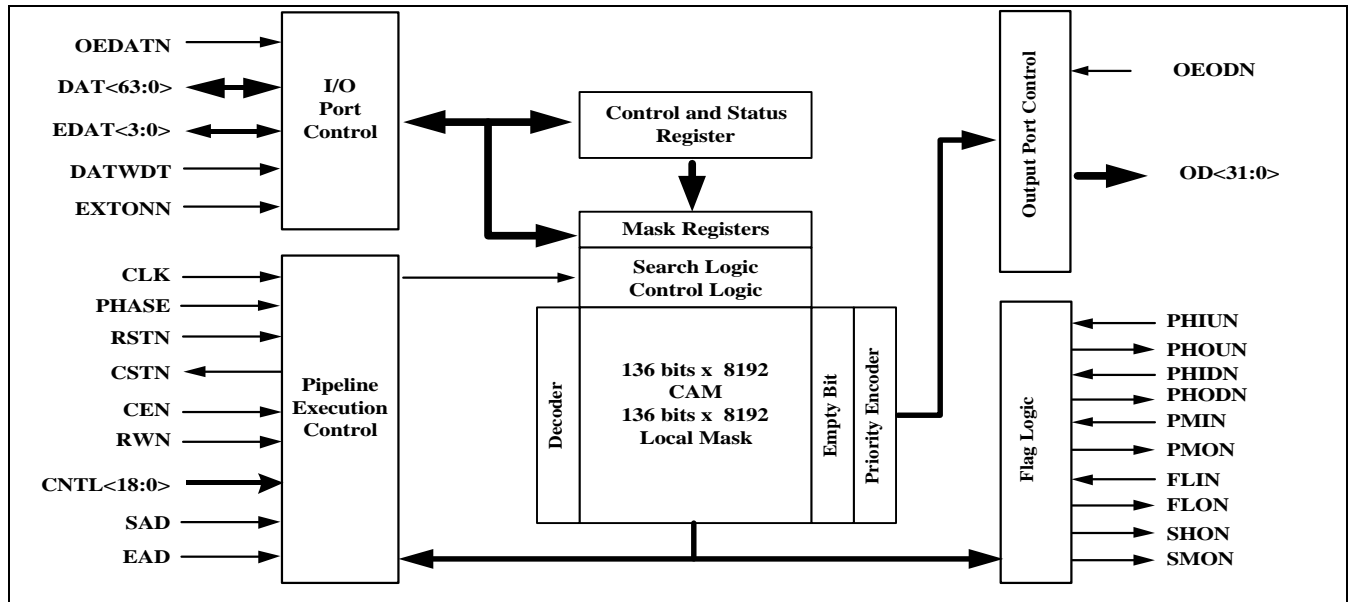
**Kawasaki LSI USA, Inc.**

Silicon Valley Office: 2570 North First Street, Suite 301
San Jose, CA 95131
Tel: (408) 570-0555
Fax: (408) 570-0567

www.klsi.com

Eastern Office: 501 Edgewater Dr., Suite 510
Wakefield, MA 01880
Tel: (781) 224-4201
Fax: (781) 224-2501

Kawasaki LSI assumes no responsibility of liability for (1) any errors or inaccuracies contained in the information herein and (2) the use of the information or a portion thereof in any application, including any claim for (a) copyright or patent infringement or (b) direct, indirect, special, or consequential damages. There are no warranties extended or granted by this document. The information herein is subject to change without notice from Kawasaki LSI.

Timing Chart of Search Operation (68bit)

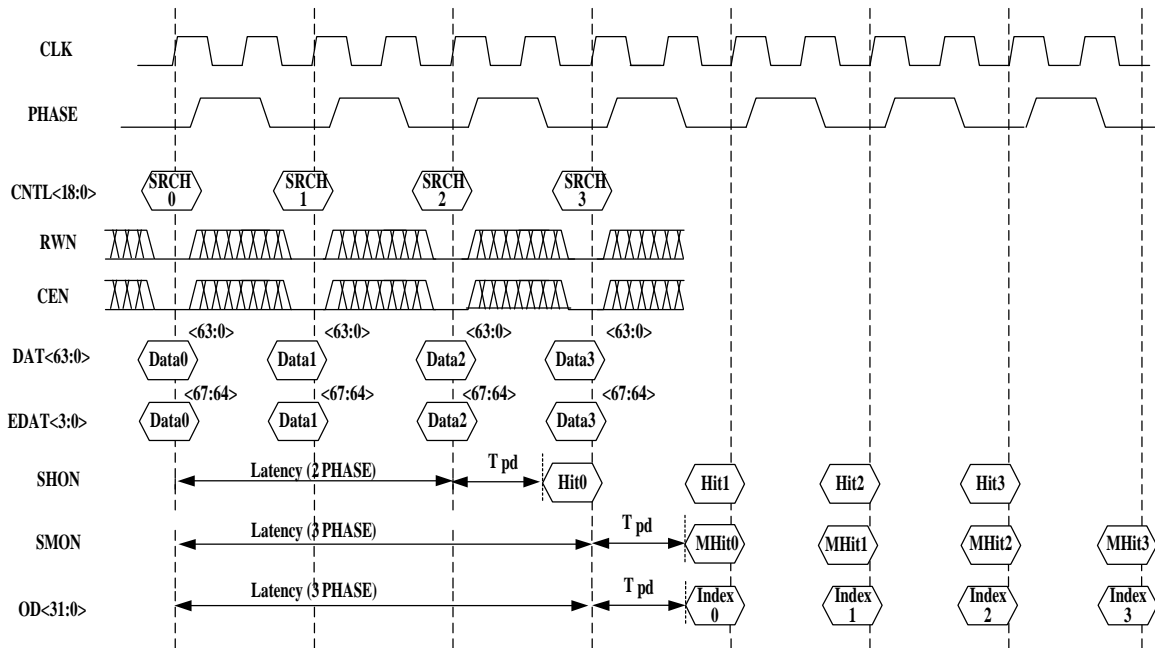

Timing Chart of Read/Write Operation (68bit)

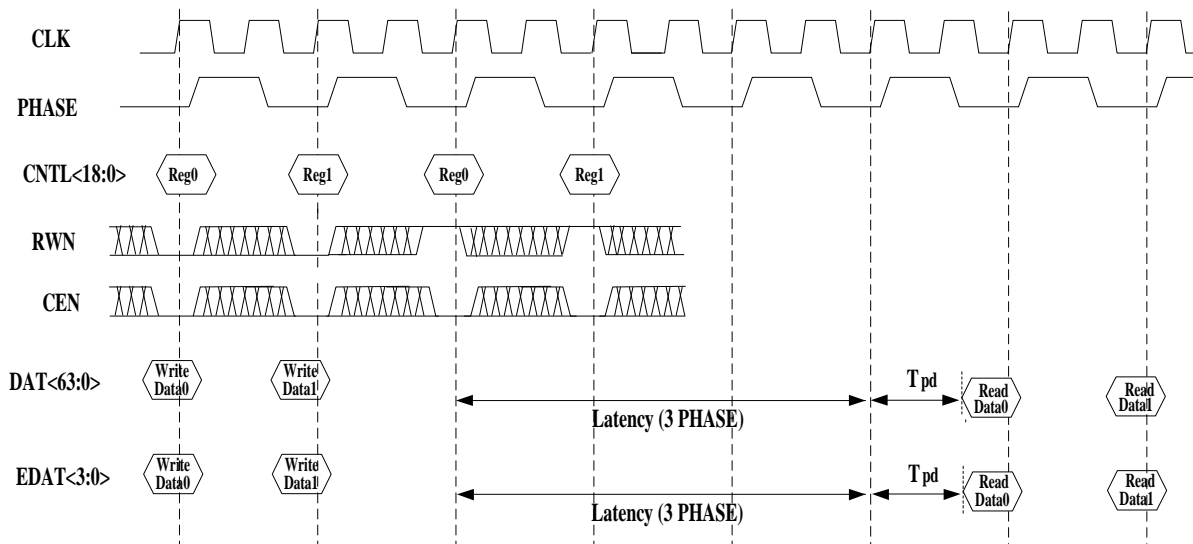

Kawasaki LSI USA, Inc.

www.klsi.com

Silicon Valley Office: 2570 North First Street, Suite 301
 San Jose, CA 95131
 Tel: (408) 570-0555
 Fax: (408) 570-0567

Eastern Office: 501 Edgewater Dr., Suite 510
 Wakefield, MA 01880
 Tel: (781) 224-4201
 Fax: (781) 224-2501

Kawasaki LSI assumes no responsibility of liability for (1) any errors or inaccuracies contained in the information herein and (2) the use of the information or a portion thereof in any application, including any claim for (a) copyright or patent infringement or (b) direct, indirect, special, or consequential damages. There are no warranties extended or granted by this document. The information herein is subject to change without notice from Kawasaki LSI.